

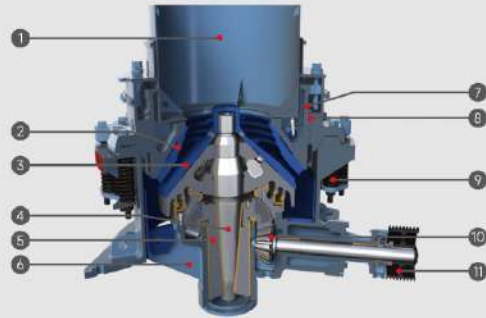

Trituradora de cono- Serie SC

Componentes principales



- 1 TOLVA DE ALIMENTACIÓN
- 2 CÓNCAVO
- 3 MANTO
- 4 EXCÉNTRICO
- 5 EJE EXCÉNTRICO
- 6 BASTIDOR
- 7 CUHARÓN
- 8 ANILLO DE AJUSTE
- 9 RESORTE
- 10 ENGRANAJE Y PIÑÓN
- 11 POLEA

Dimensiones generales

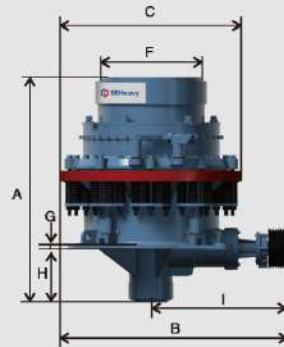
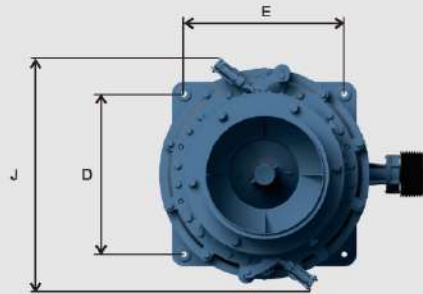

Model	SC110	SC185	SC220	SC320	SC400
Elevación máxima durante el mantenimiento (kg)	1950	3320	4500	7850	14000
Peso (kg)	12500	20000	26120	50000	80000
Potencia del motor (kW)	110	185/200	220	355	450
Dimensiones generales (mm)					
A	2390	2850	2920	3447	4200
B	2260	2740	2860	3800	4680
C	Φ1760	Φ2200	Φ2267	Φ2922	Φ3490
D	1370	1650	1765	2100	2500
E	1370	1650	1765	2100	2500
F	Φ970	Φ1220	Φ1300	Φ1600	Φ2000
G	48	50	52	65	65
H	535	750	650	791	1100
I	1375	1650	1708	2340	2935
J	1848	2400	2400	3200	4020

Nota: El peso incluye la trituradora básica y motor con fijación de anclaje, correas trapecoidales para accionamiento, armario de control, soporte del motor, unidad de lubricación con mangueras, elementos de fijación

Curva de gradación del producto

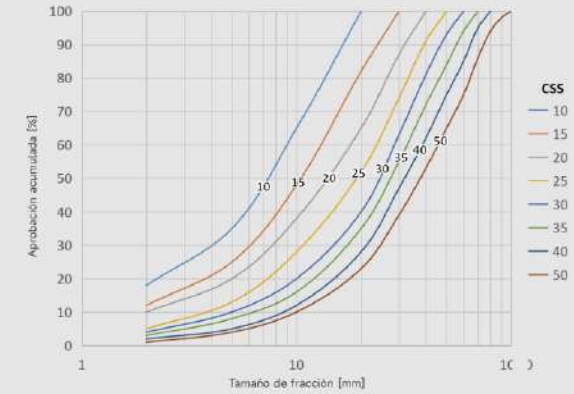

Model	Tamaño máx. del material de alimentación (mm)				
	SC110	SC185	SC220	SC320	SC400
T	190	200	230	320	360
B	170	180	210	250	310
Z	120	145	160	195	220
X	90	/	120	155	180
DT	65	95	110	130	160
D	40	80	90	100	130
DZ	25	40	45	70	90
DX	15	25	30	50	60

Nota: T = extra grueso, B = estándar, Z = medio, X = fino, DT = cabeza corta extra grueso, D=cabeza corta, DZ=cabeza corta mediana, DX=cabeza corta fina.

Model	setting (C.S.S)	Capacity (t/h)										
		5mm	10mm	15mm	20mm	25mm	30mm	35mm	40mm	45mm	50mm	
SC110	setting (C.S.S)	5mm	10mm	15mm	20mm	25mm	30mm	35mm	40mm	45mm	50mm	
		40-50	60-80	85-105	105-125	135-155	145-165	165-185	180-200	190-210		
SC185	setting (C.S.S)	6mm	10mm	15mm	20mm	25mm	30mm	35mm	40mm	45mm	50mm	
		60-70	95-115	125-140	170-190	210-230	220-250	260-290	300-340	320-360		
SC220	setting (C.S.S)	6mm	10mm	15mm	20mm	25mm	30mm	35mm	40mm	45mm	50mm	
		80-95	120-140	160-185	190-220	240-270	285-315	320-350	370-400	400-430	420-450	
SC320	setting (C.S.S)	9mm	15mm	20mm	25mm	30mm	35mm	40mm	45mm	50mm	65mm	75mm
		180-195	265-290	315-340	370-390	440-470	520-550	560-590	600-630	620-660	780-820	870-910
SC400	setting (C.S.S)	10mm	15mm	20mm	25mm	30mm	35mm	40mm	45mm	50mm	65mm	80mm
		300-320	380-410	480-510	580-610	640-670	720-750	840-880	890-930	950-990	1170-1220	1370-1440

Nota: Los datos de la tabla sólo son indicativos de las capacidades basadas en una densidad de masa de material de 1,6 t/m³ y un funcionamiento en circuito abierto. Las capacidades reales están sujetas a factores como las propiedades físicas del material de alimentación, el método de alimentación, el tamaño del material de alimentación, etc.