

Multiple Applications

- SEM660D can be widely used in port cargo handling, mineral yards, steel mill, and other high productivity demand applications
- In aggregate site, coal loading and construction etc loosen material handling utilization applications, SEM660D can load more, move faster and burn less
- Multiple work tools for selection



Work Tool Options



Main Specifications

Items		SEM660D	Items		SEM660D
Main Specifications			Engine		
Rated Load	kg	6 000	Model		WD10G240
Operating Weight with Standard Bucket	kg	20 000	Rated Power	kW	178
Bucket Capacity	m ³	3.3-5.5	Rated Speed	r/min	2 000
Wheel Base	mm	3 350	Displacement	L	9.726
Overall Dimension (outside of tire)	mm	8 414X3 370X3 458	Implement Hydraulic		
Operating Specifications			Implement System Type		
Breakout Force (GRD)	kN	183	Implement System Type		Single load sensing flow sharing system
Dump Clearance	mm	3 048	Boom Raise Time	s	5.3
Articulated Angle	°	38±1	Hydraulic Cycle Time (rated payload)	s	9.7
Transmission			Brake System		
Transmission Type		Countershat, power shift	Service Brake		Dry & caliper, air to oil control
Transmission Gears		F4/R4	Parking Brake		Drum type shoe brake, spring applied & oil released
Torque Converter Type		Single stage 3 elements	Steering System		
Maker & Type		TR200	System Type		Flow amplifying
Forward I/ Reverse I	km/h	7.4/7.4	Steering Pump Type		Piston pump
Forward II/ Reverse II	km/h	14/14	System Pressure Setting	Mpa	18
Forward III/ Reverse III	km/h	22/22	Steering Angle (L/R)	°	38±1
Forward IV/ Reverse IV	km/h	38/38	Tires		
Axle			Size		23.5-25
Main Drive Type		Spiral bevel gear, single stage	Type		Bias
Final Drive Reduction Type		Planetary type, single stage	Layer		20
Rear - Oscillating +/-	°	±11	Layer		20
			Textured Type		L3/E3

Machine Dimensions

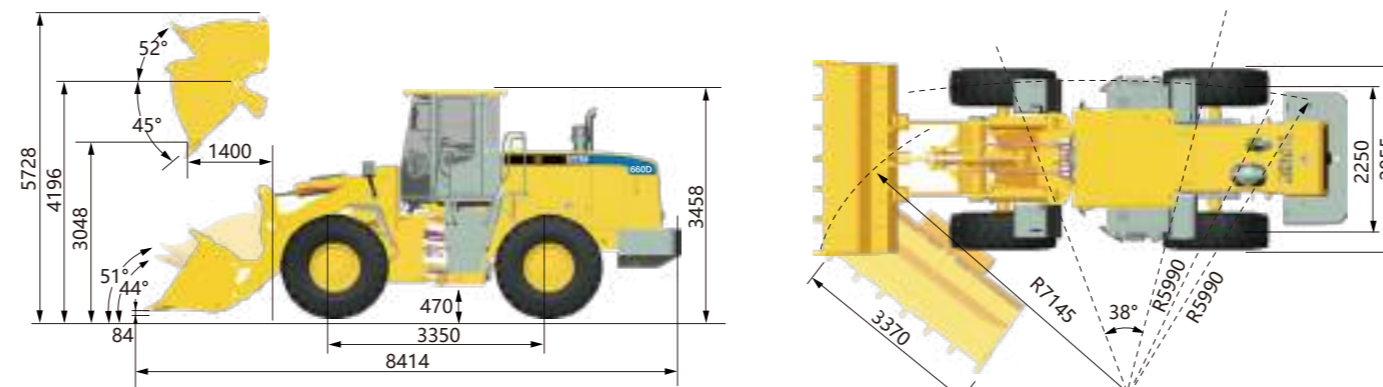

► Note: the above dimensions are based on the standard configuration.

Caterpillar (Qingzhou) Ltd. Address: No.12999 Nanhuan Road,Caterpillar Industrial Park, Qingzhou City,Shandong Province, Zip Code: 262500 P.R.China
 © Materials and specifications are subject to change without notice. Featured machines in photos may include optional equipment. See your SEM dealer for available options.
 © 2016 Caterpillar (Qingzhou) Ltd. All Rights Reserved. SEM Machinery, SEM, their respective logos, trade dress as well as corporate and product identity used herein, are trademarks of Caterpillar (Qingzhou) Ltd. and may not be used without permission.
 Version: September 2016

SEM660D Wheel Loader



SEM660D

Product Advantages

- Excellent Fuel Economy
- Best-in-class Reliability and Durability
- High Productivity
- Outstanding Operation Comfort

Website <http://www.semmachinery.com>



Optimized Engine

- Low speed engine with E-fan provides increased operating efficiency
- Enhanced fuel pre-filter eliminates water and contaminant from fuel for best fuel system protection
- The 93 desert type air cleaner provides machine reliability in most severe applications. Oil-bath type oil filter is optional



Efficient Hydraulic System

- The advanced load sensing hydraulic system with flow sharing circuits improves efficiency
- World Class hydraulic components ensure high reliability
- The optimized hydraulic system paired with the drive train reduces machine cycle time and increases productivity
- Relocated hydraulic oil tank ensures hydraulic pump's life

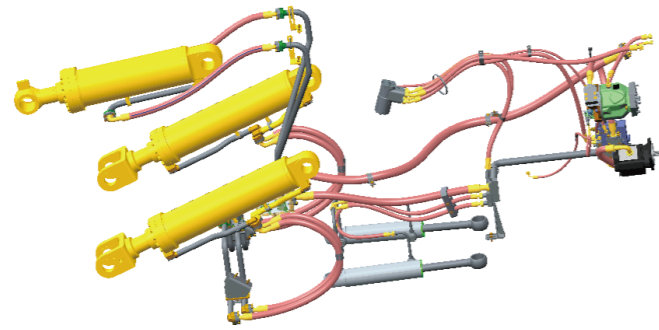

Operator Station

- Premium operator station improves cab sealing and visibility
- Sliding side window and AC with fresh air circulation provide operator comfort
- Integrated relays and fuse panel. Single cabin harness connection plug provides easy service access
- Joystick hydraulic control for easy and precise operation
- Multi-function instrument dashboard with 3-level alarm
- Adjustable suspension seat



Reliable Drivetrain

- Countershaft transmission with upgraded core components provides high reliability
- Large rim-pull in 1st gear and higher speed in 2nd gear provide high efficiency for load and carry applications
- Clutch cutoff selection switch ensures stable and safe operation
- The SEM designed and built axle equips with 10 calipers (6 for front and 4 for rear), it delivers better brake performance and longer service life



Advanced Cooling System

- The standard cooling package provides high reliability in 43°C ambient conditions. An optional package is available for 50°C ambient conditions
- Shock pad mounts ensure reliability under severe applications



Solid Structure

- Structures undergo Finite Element Analysis (FEA) and On Machine Stress Analysis (OMSA) to ensure durability
- Performance Series (PS) buckets improve loading capability
- Steering rubber stopper design provides protection for frame



Serviceability

- Torque converter is isolated from transmission making it easy to service
- Simple structure countershaft transmission delivers low maintenance cost
- Centralized lubrication points reduce maintenance time
- System pressure test ports are standard
- Easy access to external air charge connecting port
- Engine hood grill opens for easy service access
- It is easy to change brake discs with new split type caliper



Safety

- Safety design complies with all regulatory requirements
- Caterpillar Production System (CPS) leveraged in manufacturing process
- 3-point touching design provides convenient operator entering to cabin
- Backup alarm and beacon ensure machine safety
- Environment-friendly painting process

