

# LUX SOLAR



LED FLOODLIGHTS | 4 X 65 W (IP69K)  
ILLUMINATED AREA | 2400 m<sup>2</sup>



VERTICAL TELESCOPIC MAST  
MAX HEIGHT | 8.5 m  
LIFETIME WARRANTY



BATTERY PACK | N.2 UNITS  
AGM 24V DC - 260 Ah  
EXPECTED OPERATION | 20 HRS



DEDICATED FRONTAL PANEL  
BATTERY CHARGER  
MANUAL | AUTO MODE  
LIGHT SENSOR



N.2 SOLAR PANEL  
WATTAGE | 330 W EACH



GALVANIZED METAL BODY  
80 µm POWDER COATING



MADE IN  
ITALY

LUX TOWER   
lighting towers

# Lux Green Series LUX Solar

MADE IN  
ITALY

## TECHNICAL DATA

### Dimensions & weight

Dimensions min.	mm	3215 X 2040 X 2750
Dimensions max.	mm	3640 X 2600 X 8500
Total weight without fuel	Kg	785

### Features

Floodlight	W	4 X 65 W
Lamps type	W	Led
Floodlight IP level		69K
Mast Rotation		340°
Lifting method		Manual
Wind stability	km/h	80

### Solar Panel

Model		Monocrystal Silicon
Quantity	n	2
Wattage	W	330
Solar charger control		MPPT 100-30
Solar panels deployment		Manual - Fix Inclination 26°

### Battery Pack

Type		AGM
Number of units	n	2
Battery Pack Power		24VDC – 260Ah
Expected battery cycles	n	500
Running Time	h	20
Charging time (Led Off)	h	9

### Loading Plan

#### Disassembled and stacked



40' HC Container	15 Units
20' Container	4 Units
Truck	18 Units

**SUPER SILENT**

**NO MAINTENANCE**

**NO FUEL COSTS**

**NO EMISSIONS**

### Illuminated Area

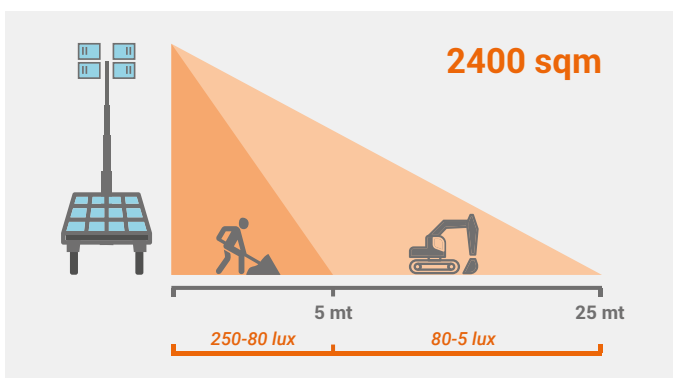

**20 HRS**  
**RUNNING TIME**



**MANUAL | AUTO**  
**MODE**



**LIGHT SENSOR**

### CONTROL PANEL



- Battery Status -
- External power source spy -
- Lamps hour meter -
- Light sensor relay -
- Lamp switches -

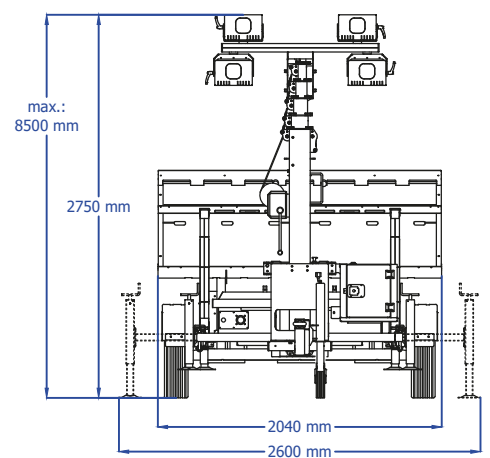
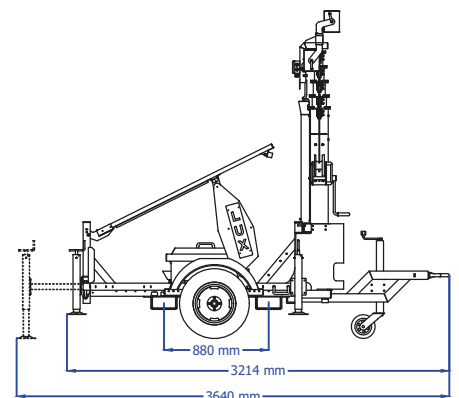

**LUXTOWER**  
lighting towers

Luxtower: Via Strada Nuova, 28 - 27050 Codevilla (PV) ITALY | TLF. +39 0383 365544 | Fax +39 0383 49702

LUXTOWER ongoing policy is in continuous improvement. The company reserves the right to modify the technical specifications and items described in this catalogue at any time and without notice for technical or commercial reasons. Product images are shown for information only. LUXTOWER® - 2016© All rights reserved.